

# A Wireless Sensors Network For Monitoring Environmental Variables in a Tomato Greenhouse

Marco Mancuso  
Rinnovando S.r.l.  
Via 4 Aprile, n. 37  
97019 Vittoria (Ragusa)  
marco.mancuso@rinnovando.it

Franco Bustaffa  
Nemo S.r.l.  
Via delle Pianazze, n. 74  
19136 La Spezia  
f.bustaffa@nemosrl.it

## Abstract

*Precision Agriculture is based on detailed information on the status of crops: for example, some of the processes like fertilization and especially crop protection require frequent updates in information. Wireless sensors, continuously acquiring data, could play a role in preserving the environment by reducing pesticide usage and maximizing quality. These benefits need to be tested in the field.*

*The Rinnovando group (Rgroup) is working with agricultural experts on a short-term deployment of a wireless sensors network in a tomato greenhouse in the South of Italy. In this project, Sensicast devices are used in order to apply of Wireless Sensor Networks (WSN) in agriculture and particularly that of microclimate monitoring within a greenhouse incorporating sensor nodes in an agricultural ICT infrastructure.*

## 1. Introduction

By densely monitoring climatic and pathological conditions, research have the specific purpose of establishing correlation between sensors' signals and reference measurements and helping farmers to improve crop quality.

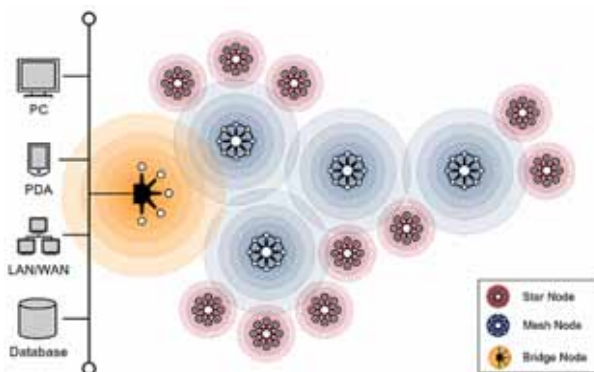

Figure 1. Sensicast WSN

The choice of Sensicast products is for the reliability, the transmission range, the easy and powerful interface and the possibility to create nodes with special features.

Sensicast Systems, Inc., [www.sensicast.com](http://www.sensicast.com), Needham, MA, founded in 2002, is the leading provider of end-to-end wireless mesh sensor networks systems and technology to integrators and original equipment manufacturers in the industrial and building monitoring markets. Sensicast's patented technology combines next generation deployment flexibility with wireless data-sensor networks that deliver superior reliability, even in the harshest environments.

## 2. Precision Agriculture Scenario

In the past few years, new trends have emerged in the agricultural sector. Precision agriculture concentrates on providing the means for observing, assessing and controlling agricultural practices. It covers a wide range of agricultural concerns from daily herd management through horticulture to field crop production. It concerns as well pre- and post-production aspects of agricultural enterprises. Precision agriculture aims at making cultural operations more efficient, while reducing environmental impact. On the conceptual point of view, precision agriculture can be considered as a three-phase cycle.

The first phase is data collection. It also comprises the measurement (which can be more or less automated) of parameters characterising the soil and the growing crops.

The second phase is the data interpretation. This step is not yet automated, that means the decision making devolves to the farmer, who has to make choices.

The third phase is the application. It involves the adjustment of sowing parameters, the modulation of fertilisers doses, the site-specific application of herbicides, etc.

A promising application of WSN is in the instrumentation of farming areas to collect and correlate data which can be used to enhance crop yields [1], [4]. In the Rgroup, the goal is to understand the impact of correlation criteria in the overall management of a cultivation. The main goal of monitoring is to reveal when the crop is at risk of developing the disease and let

the farmer treat the field or parts of it with pesticide/fertiliser only when absolutely needed.

The Rgroup objectives are:

- to establish correlation between sensors' signals and reference measurements;
- to develop an architecture for decision support systems in agriculture, based on wireless sensor networks as an extension of a rural communication infrastructure;
- to develop more accurate disease models helping farmers to improve crop quality.

### 2.1. Greenhouse structure and environmental control

Traditionally, greenhouses have been made from glass. However, glass is expensive, heavy, hard to work with, and relatively inefficient in terms of energy conservation. Rigid clear plastics used in greenhouse construction, include fibreglass reinforced polyester, polycarbonate, acrylic (polymethacrylate) and polyvinyl chloride panels. Although some of these are energy efficient and have good light transmission, and last at least 10 years, they are more expensive than polyethylene films. Thus, it is more common for new greenhouses to be covered with a double layer of polyethylene film than with glass or rigid plastic panels.

Changes in temperature, humidity, light, and other greenhouse conditions can have a profound effect on the productivity and quality of plant growth. By continuously monitoring numerous environmental variables at once, a grower is better able to understand how growth conditions are fluctuating, and react to those changes in order to maximize efficiency.

Tomato is the most commonly-produced greenhouse vegetable crop in the South of Italy. Accurate temperature, humidity, and carbon dioxide control are important[2].

The optimal level of the air temperature in the greenhouse depends on the photosynthetic activity of the plant in question, under the influence of the intensity of solar radiation on disposal (i.e., for each light intensity, there is an optimal air temperature, enabling maximum photosynthetic activity).

Soil temperature influences the energy balance of the plant canopy, too. The influence is by conduction heat transfer directly between the soil structure and through convection between the plant roots and water flow around them.

Through a great number of experiments and investigations, it is proven that:

- Optimal soil temperature depends on the stage of development of the plant in question;
- Optimal soil temperature depends on the light intensity available, and
- Soil temperature influences the value of the optimal air temperature (i.e., higher soil temperature requires lower air temperature and vice versa).

	<i>Optimal Soil Temperature Intervals</i>	
<i>Phase of Development</i>	<i>Low Intensity of Light (°C)</i>	<i>Strong Intensity of Light (°C)</i>
<i>Development before flowering</i>	13-14	17-20
<i>Flowering</i>	15-16	19-22
<i>Harvesting</i>	20-22	23-25

**Table 1. Optimal Soil Temperatures for the Tomato Culture**

Environmental control is accomplished in many ways ranging from totally manual, to sophisticated computer-assisted control. Computers are also used to monitor fertilizer and water applications. Energy conservation features, including the use of double polyethylene film, have increased greenhouse relative humidity. Although computer control systems are designed to monitor and can control humidity, it is not always clear what levels are desirable in terms of plant growth, fruit set, and disease prevention. Also, humidity control is indirect and usually involves tradeoffs with air and leaf temperatures, CO<sub>2</sub>, and ventilation. A major consideration in environmental control is that of providing temperature and humidity conducive to active movement of water and nutrients through the plant for optimum growth.

High humidity and warm temperatures in tomato greenhouses provide a favourable environment for development of certain diseases. The diseases listed below are much more likely to occur inside greenhouses than outdoors [6]:

- Gray mould
- Leaf mould
- Powdery mildew

WSN could be used to control and maintain temperature, relative humidity, and CO<sub>2</sub> concentrations within optimal limits even in relatively small greenhouse ranges. However, the limitations on such applications are that these factors cannot be controlled independently, especially in warm climates. For example problem is that for many of these factors, especially under high light and temperature conditions, and high vapour pressure deficit, it is not clear what conditions are stressful to the plant.

In the past years, much of the modelling work has been conducted in Northern Europe or Canada and there is little data to indicate, for example, the trade-off between cooling costs, and yield reductions. The Rgroup started in the South of Italy in order to apply the possibility of WSN in agriculture and particularly that of microclimate monitoring within a greenhouse incorporating wireless sensors in an agricultural ICT infrastructure.

## 2.2. Experimental setup in a tomato greenhouse

Wireless Sensors can form a dense network and provide the possibility for continuous monitoring of relevant parameters in a dense grid for a reasonable price, providing a decision support system (DSS) for delivering insight into possible treatments, field-wide or for specific parts of a field, the means for taking differential action, for example, varying in real-time an operation such as fertilizer, lime and pesticide application, tillage, or sowing rate [3].

Challenges of the implementation of a wireless network are due to the fact that large-scale greenhouses have large distributed areas, high variance of temperature and humidity. Thus it is difficult to lay wires and power supplements. On the other hand, the workload of wired equipment installation and maintenance is heavy. In large-scale greenhouses, transmitting signals with wires is not suitable. Finally, the network made up of wireless sensor nodes has some good characters such as mobility, reliable stability and good maintainability.

We present the setup of the Rgroup that concentrates on monitoring micro-climates in a tomatoes greenhouse. Poor light intensity and high humidity often result in poor fruit set and quality. Proper control of plant disease is critical in greenhouse environments, where high temperatures and humidity are ideal for diseases to develop. Insect and nematode infestations, too, can become rampant under the confined greenhouse conditions.

The Rgroup has designed a complete data acquisition system developing a LabView (National Instruments) virtual instrument in order to allow simultaneous acquisition of three different signals coming from each sensor of a WSN. The sensors network is a grid of wireless nodes organized as depicted in Fig. 2. In a tomato greenhouse of 20 by 50 meters, six nodes were employed and arranged in two rows, 12.5 m apart.

The mutual distance between the nodes in the rows is 6.5 m. The nodes are placed in the bottom of the field with an average height of 0.25 m.

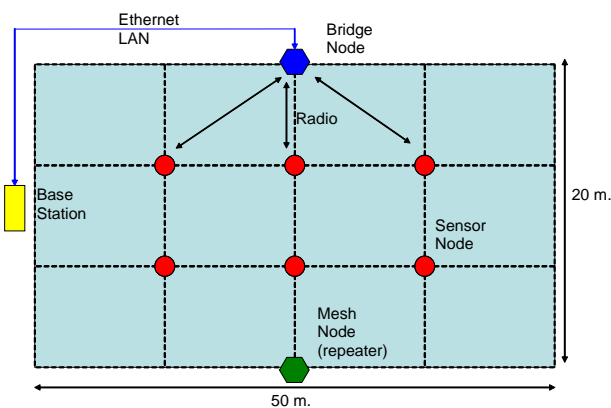

**Figure 2. Sensors field structure for the experiment**

To further improve communication, the bridge is installed at a height of 65cm. A total of 7 nodes, including the bridge, have been installed and manually localized so that a map of the parcel has been created. Of course this layout may be extended to a lot of near greenhouses using MESH200 (repeater) nodes.

Especially temperature and humidity of the air is a major factor in the development of the micro climate. The battery powered nodes are equipped with sensors for registering the air temperature and relative humidity and the soil temperature (Fig. 3). Each node is able to transmit/receive packets to other nodes inside a well defined transmission range. A single node transmit the temperature and relative humidity every minute.



**Figure 3. RTD204**

The standard Sensicast RTD204 node, available in the market, will be modified to include a SHT71 Sensirion sensor for air temperature and humidity (at the moment it is used an EMS200 with SHT71 and RTD204). The node firmware will also be modified to support this sensor with the help of Sensicast engineers. For soil temperature is used a 4 wire PT100 platinum waterproof sensor. This sensor have the body in PVC to eliminate galvanic current problems and is produced by MTX Italia. In this way a single “RTD-Hybrid” will measure the air temperature and humidity and from 1 to 4 soil temperatures. The range node is of up to 70 meters inside and up to 212 meters outside in clear line of sight and at one minute intervals, the battery life is up to one year. The transmission protocol is the patented SensiNet™. At 2.4GHz, SensiNet™ supports IEEE 802.15.4 radios (which are Direct Sequence Spread Spectrum radios) with frequency hopping modulation techniques applied as well. Using frequency diversity, SensiNet™ overcome ZigBee that has a restricted output power in Europe due to regulatory constraints.

Another aspect very important in farm environment is the easy node installation (automatic network joining) and management (automatic low-battery reporting, heartbeats, wireless firmware upgrade capability ...).

The data collected by the sensors is gathered at the edge of the greenhouse and further transferred via LAN to a laptop computer (base station) for data logging and correlation.

In the near future the data collected will be transferred from a base station to a Server, via WiFi, for data logging and correlation. The Server will be connected via LAN to the Internet and data will be uploaded to a Web server under XML format.

A knowledge-based decision support system will be developed using expert system techniques to select the best combination of crops over a period of time for the regions of South Italy. This system will consist of many different sub-knowledge bases with several hundred production rules. The program will combine heuristics with computer graphics and hypertext in the application environment to design an optimum cropping plan. As well as incorporating the knowledge and experience of experts, this program will include public knowledge about each of the crops and their management. This system will provide a consistent, satisfactory level of answers to people who need to choose their cropping options.

### 2.3. Relevant results

The first application focused on measuring the microclimate of a tomato crop to deliver detailed information for a novel decision support system that help farmers to improve crop quality.

The example application being deployed deals with fighting a fungal disease in a tomato field. The development and associated attack of the crop depends strongly on the climatological conditions within the greenhouse. Humidity is an important factor in the development of the disease. Both temperature and whether or not the leaves are wet are also important indicators. To monitor these critical factors, we instrumented a tomato greenhouse with Sensicast wireless sensors.

Earlier deployments have shown that the radio range is reduced when the tomato crop is flowering. In spite of the fact that the location of the sensors can be determined during placement, a positioning method is good to verify and correlate the origin of the obtained information. The relationship between air temperature and humidity, denoted as the greenhouse climate, are intensively non-linear and coupled.

### 2.4. Conclusions and related work

Research had the specific purpose of establishing correlation between sensors' signals and reference measurements. The experiments conducted in this study demonstrated that:

- the reliability of the wireless sensor network is of great importance as we want to prevent the loss of data and statistics. The high reliability is one of the main reasons that Sensicast wireless mesh nodes were selected.
- The Rgroup proactive operational software will generate a new round of productivity gains and opportunities to enhance the quality of crops [5].
- In near future correlation maps of measured signals will enhance our novel Decision Support System.

Regarding the development of the Rgroup operational software for such networks, the focus will be on the enhancement of the correlation system through the use of advanced techniques that use fuzzy logic principles. In June, we expect to have preliminary measurements data and statistics.

Next challenges will involve different aspects of the Rgroup such as Installation, Configuration, Maintenance, Discovery and Reconfiguration.

In addition, we desire investigating ways of compressing the data to save more energy on radio communication.

### References

- [1] Ning Xu, "A Survey of Sensor Network Applications", Computer Science Department, University of Southern California.
- [2] Kamenev, P. N. "Otoplenie I Ventilacija", Strojizdat, Moskva, 1975
- [3] Laurenson M, Kiura T, Ninomiya S, "Providing agricultural models with mediated access to heterogeneous weather databases", Appl. Engin. Agric. Vol. 18, pp 617-625, 2002
- [4] Akyildiz I. F., Su W., Sankarasubramaniam Y., Cayirci E., "Wireless Sensor Networks: A Survey. Computer Networks", Vol. 38(4), pp393-422, March 2002.
- [5] Tennenhouse D., "Proactive Computing" Comm. ACM, vol. 43, no. 5, pp 43-50, May 2000
- [6] Mark L. Gleason and Brooke A. Edmunds, "Tomato diseases and disorders", Department of Plant Pathology – Iowa State University, May 2005